

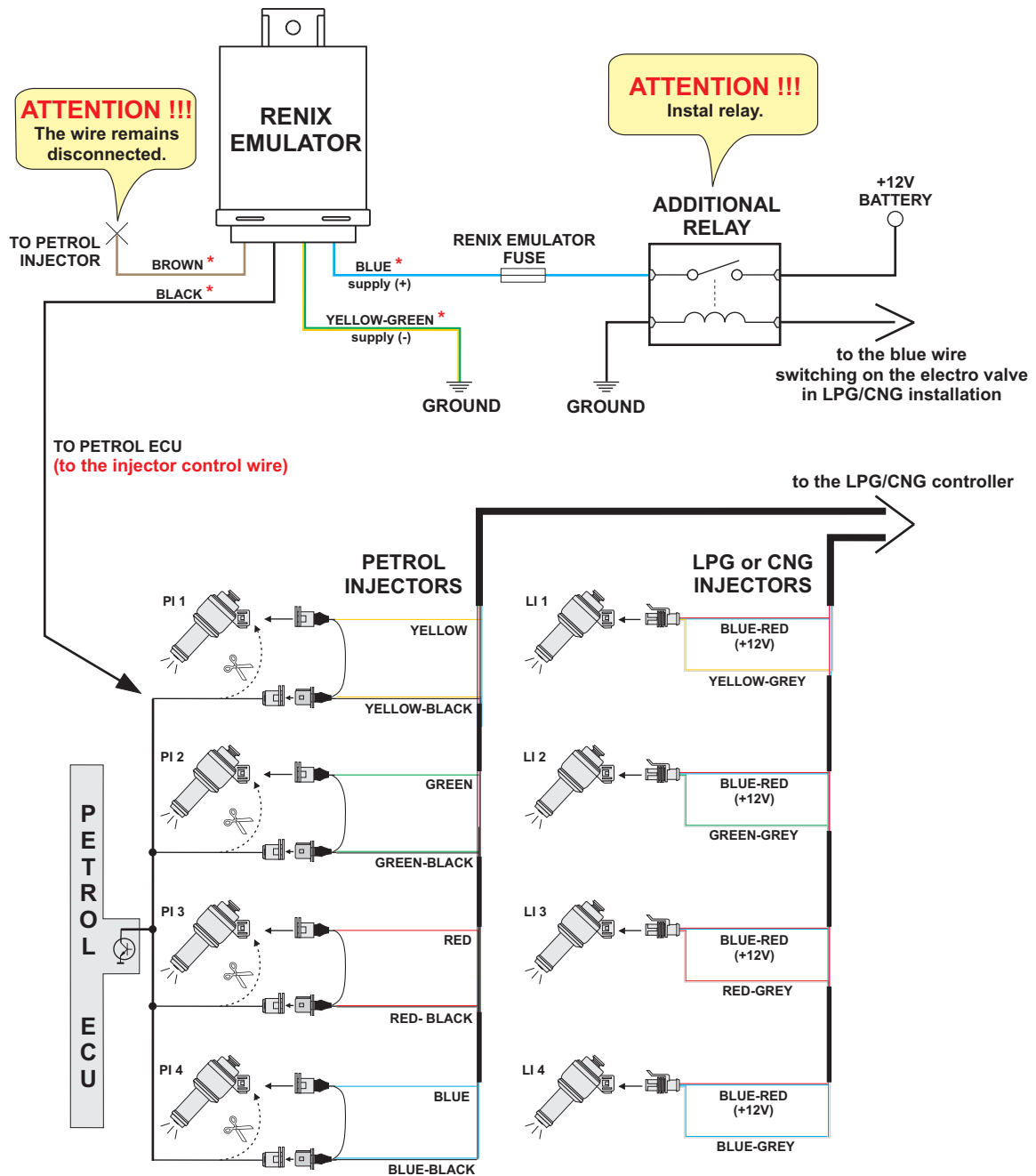

RENIX. TYPE CONNECTION.



* - the colors of RENIX emulator wires may be different depending on different manufacturers.

In case there are two separate control wires from the petrol ECU (i.e. resistance measured between control wires $\neq 0$) use separate RENIX emulator for each control wire as shown in diagram. Choose "RENIX" type injection in controller configuration program. For older controllers (up to version 1.10) order "RENIX" type controller. In controller configuration program set "0" under "cylinder switchover".